

Зип Общепит

vsezip.ru

DESPIECE TECNICO

+7(812)987-08-81

Fry-tops eléctricos
Electric fry-tops
Fry-tops électriques
Elektro griddle-platten
Fry-tops eletricci
Fry-tops elétricos

GAMA 900

Modelos:

FTE9-05

FTE9-10



PLATON SERVICE

8 (800) 500-34-41

www.platonservice.com

Marzo 2009 March

Revisado Mayo 2014 May Revised

FAGOR



FAGOR INDUSTRIAL

Зип Общепит

vsezip.ru

+7(812)987-08-81

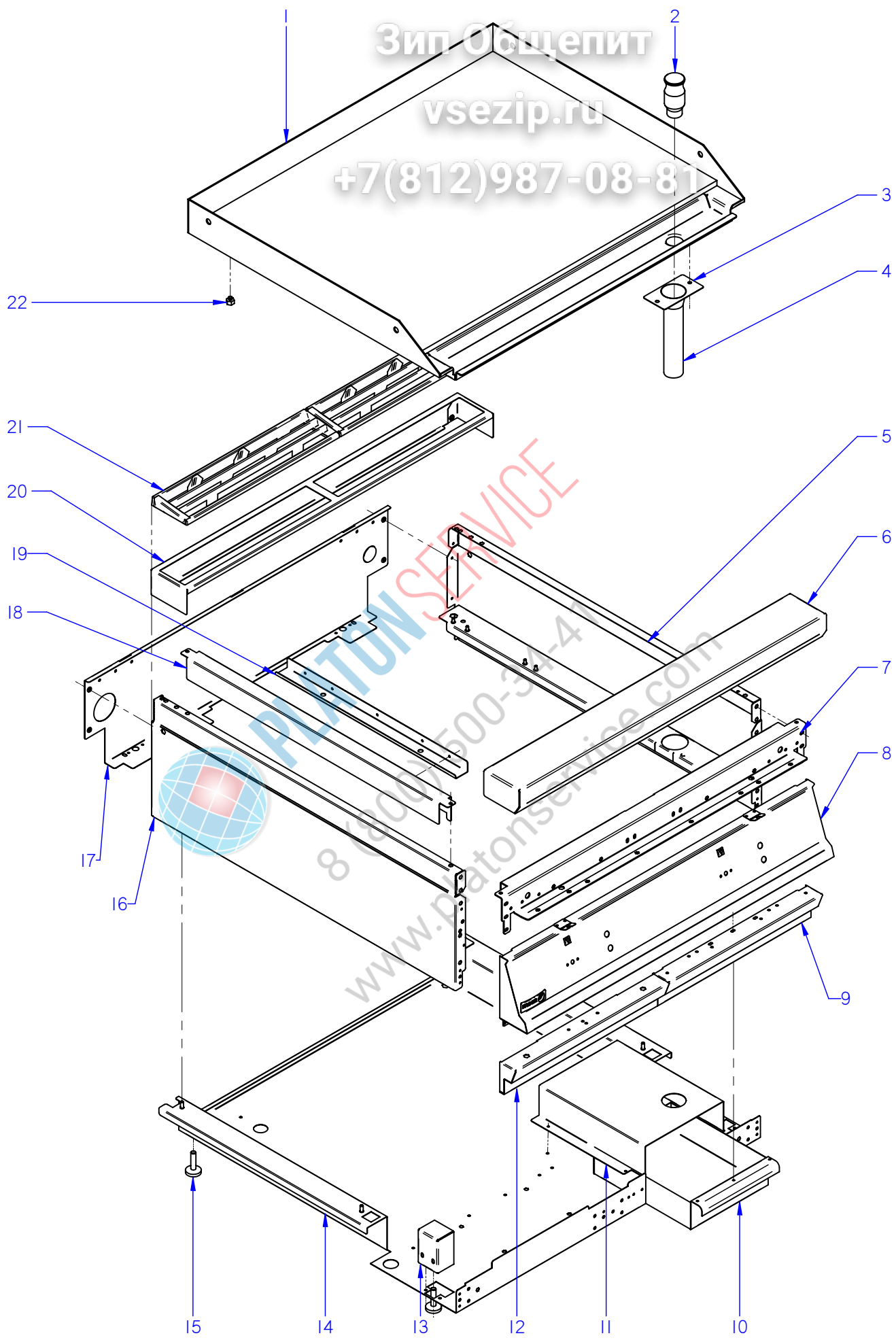

ITEM MARCADO EN COLOR = REPUESTO RECOMENDADO
COLOURED ITEM = RECOMMENDED SPARE PART

N plano	Firma	Fecha	Aparato	MUEBLE	Lamina	Fagor Industrial S.Coop. FAGOR
C-2288	<i>(Signature)</i>	2009-03	FRY-TOP FTE9-05 / FTE9-10		1	Oñate

MOD.		FRY-TOP		ZONA		MUEBLE	
ITEM	CODIGO	DENOMINACION	TEXTO	FTE9-05	FTE9-10		
1	R055401000	PLANCHA FTE9-05 L	PLATE FTE9-05 L	1	_		
1	R055403000	PLANCHA FTE9-05 R	PLATE FTE9-05 R	1	_		
1	R055402000	PLANCHA FTE/C9-05 L	PLATE FTE/C9-05 L	1	_		
1	R055404000	PLANCHA FTE/C9-05 R	PLATE FTE/C9-05 R	1	_		
1	R105401000	PLANCHA FTE9-10 L	PLATE FTE9-10 L	_	1		
1	R105403000	PLANCHA FTE9-10 R	PLATE FTE9-10 R	_	1		
1	R105402000	PLANCHA FTE9-10 L+R	PLATE FTE9-10 L+R	_	1		
1	R105404000	PLANCHA FTE/C9-10 L	PLATE FTE/C9-10 L	_	1		
1	R105406000	PLANCHA FTE/C9-10 R	PLATE FTE/C9-10 R	_	1		
1	R105405000	PLANCHA FTE/C9-10 L+R	PLATE FTE/C9-10 L+R	_	1		
2	R045415000	TAPON DESAGÜE CR-DURO	DRAINAGE CAP CHROME PLATE	1	1		
3	R152607000	SOPORTE TUBO DESAGÜE	DRAINAGE PIPE SUPPORT	1	1		
	Q302022000	ARANDELA 16X6X1.2 A.304	WASHER 16X6X1.2 A.304	2	2		
	Q162040000	TUERCA EXAGONAL M6	HEXAGONAL NUT M6	2	2		
4	R155010000	TUBO DESAGÜE FRY-TOP G-900	DRAINAGE PIPE FRY-TOP G900	1	1		
5	R062810000	PANEL LATERAL DERECHO G9-00	RIGHT SIDE PANEL G900	1	1		
	Q221342000	REMACHE EXAGONAL M5	HEXAGONAL RIVET M5	7	7		
	Q162030000	TUERCA EXAGONAL M5	HEXAGONAL NUT M5	2	2		
	Q221345000	REMACHE EXAGONAL M10	HEXAGONAL RIVET M10	2	2		
	Q419005000	REMACHE 4X8 ALMG3 / ALUMINIO	RIVET 4X8 ALMG3 / ALUMINIUM	2	2		
6	R045416000	ANTERIOR DE MESA 1/2 M	FRONT BENCH 1/2 M	1	_		
6	S105402000	ANTERIOR DE MESA 1 M	FRONT BENCH 1 M	_	1		
	Q152004000	TORN. APLASTADO M5x13 A304	FLAT HEADED SCREW M5x13	2	2		
7	X162680000	ESCUADRA AMARRE ANTER.1/2 M	FRONT FASTENING BRACKET	1	_		
7	U022605000	ESCUADRA AMARRE ANTERI.1M	FRONT FASTENING BRACKET	_	1		
	Q221342000	REMACHE EXAGONAL M5	HEXAGONAL RIVET M5	3	5		
	Q012032000	TORNILLO EXAGONAL M5X15 A304	HEXAGONAL BOLT M5X15 A304	6	6		
8	R052822000	PORTAMANDOS FTE9-05	CONTROL HOLDER FTE9-05	1	_		
8	R102804000	PORTAMANDOS FTE9-10	CONTROL HOLDER FTE9-10	_	1		
	U022836000	ESCUDO FAGOR	FAGOR EMBLEM G700	1	1		
	Q221023000	CLIP SUJECIÓN RÁPIDA Ø5	RAPID CONNECT CLIP Ø5	2	2		

MOD.		FRY-TOP		ZONA		MUEBLE	
ITEM	CODIGO	DENOMINACION	TEXTO	FTE9-05	FTE9-10		
9	H012821000	ASA BANDEJA IZQUIER.-DERECHA	SKIRTING ASA	1	1		
10	R152608000	CAJA RECOGEGRASAS	GREASE COLLECTION TRAY	1	1		
	Q419005000	REMACHE 4x8 ALMG3 / ALUMINIO	RIVET 4X8 ALMG3 / ALUMINIUM	3	3		
11	R592602000	CUBIERTA RECOGEGRASA FTE9-00	GREASE COLLECT. TRAY FTE9-00	1	1		
	Q419005000	REMACHE 4x8 ALMG3 / ALUMINIO	RIVET 4X8 ALMG3 / ALUMINIUM	4	4		
12	R062805000	ZOCALO INFERIOR FRY-TOP	SKIRTING ASA	-	1		
	Q012042000	TORNILLO EXAGONAL M6x15	HEXAGONAL BOLT M6X15	-	2		
13	H012805000	ESCUADRA AMARRE PATA	LEG FASTENING BRACKET	2	2		
	X010503000	CIERRE MUELLE	LOCK SPRING	2	2		
	Q419007000	REMACHE TUBULAR C/V Ø3,2x6	TUBULAR RIVET C/V Ø3.2X6	4	4		
	Q162030000	TUERCA EXAGONAL M5	HEXAGONAL NUT M5	4	4		
	Q262030000	ARANDELA GROW. A5 A304	WASHER GROW. A5 A.304	4	4		
14	R582801000	BASE INFERIOR FTE9-05	LOWER BASE FTE9-05	1	-		
14	R592801000	BASE INFERIOR FTG9-10	LOWER BASE FTG9-10	-	1		
	Q221345000	REMACHE EXAGONAL M10	HEXAGONAL RIVET M10	2	2		
	Q221342000	REMACHE EXAGONAL M5	HEXAGONAL RIVET M5	-	4		
15	Z200107000	PATA REGULABLE	ADJUSTABLE LEG	4	4		
	Q221345000	REMACHE EXAGONAL M10	HEXAGONAL RIVET M10	4	4		
16	R062811000	PANEL LATERA IZQUIERDO G-900	LEFT SIDE PANEL G-900	1	1		
	Q221342000	REMACHE EXAGONAL M5	HEXAGONAL RIVET M5	7	7		
	Q162030000	TUERCA EXAGONAL M5	HEXAGONAL NUT M5	2	2		
	Q221345000	REMACHE EXAGONAL M10	HEXAGONAL RIVET M10	2	2		
	Q419005000	REMACHE 4X8 ALMG3 / ALUMINIO	RIVET 4X8 ALMG3 / ALUMINIUM	2	2		
17	R152811000	PANEL POSTERIOR 1/2M	REAR PANEL 1/2M	1	-		
17	H012824000	PANEL POSTERIOR 1/2M	REAR PANEL 1/2M	1	-		
17	R162813000	PANEL POSTERIOR 1M	REAR PANEL 1M	-	1		
17	H022809000	PANEL POSTERIOR 1M	REAR PANEL 1M	-	1		
	Q419005000	REMACHE 4x8 ALMG3 / ALUMINIO	RIVET 4X8 ALMG3 / ALUMINIUM	4	4		
	X010503000	CIERRE MUELLE	LOCK SPRING	2	2		
18	R152807000	LATERAL DE MESA	BENCH SIDE	2	2		
	Q012032000	TORNILLO EXAGONAL M5X15 A304	HEXAGONAL BOLT M5X15 A304	6	6		

Зип Общепит

vsezip.ru

+7(812)987-08-81

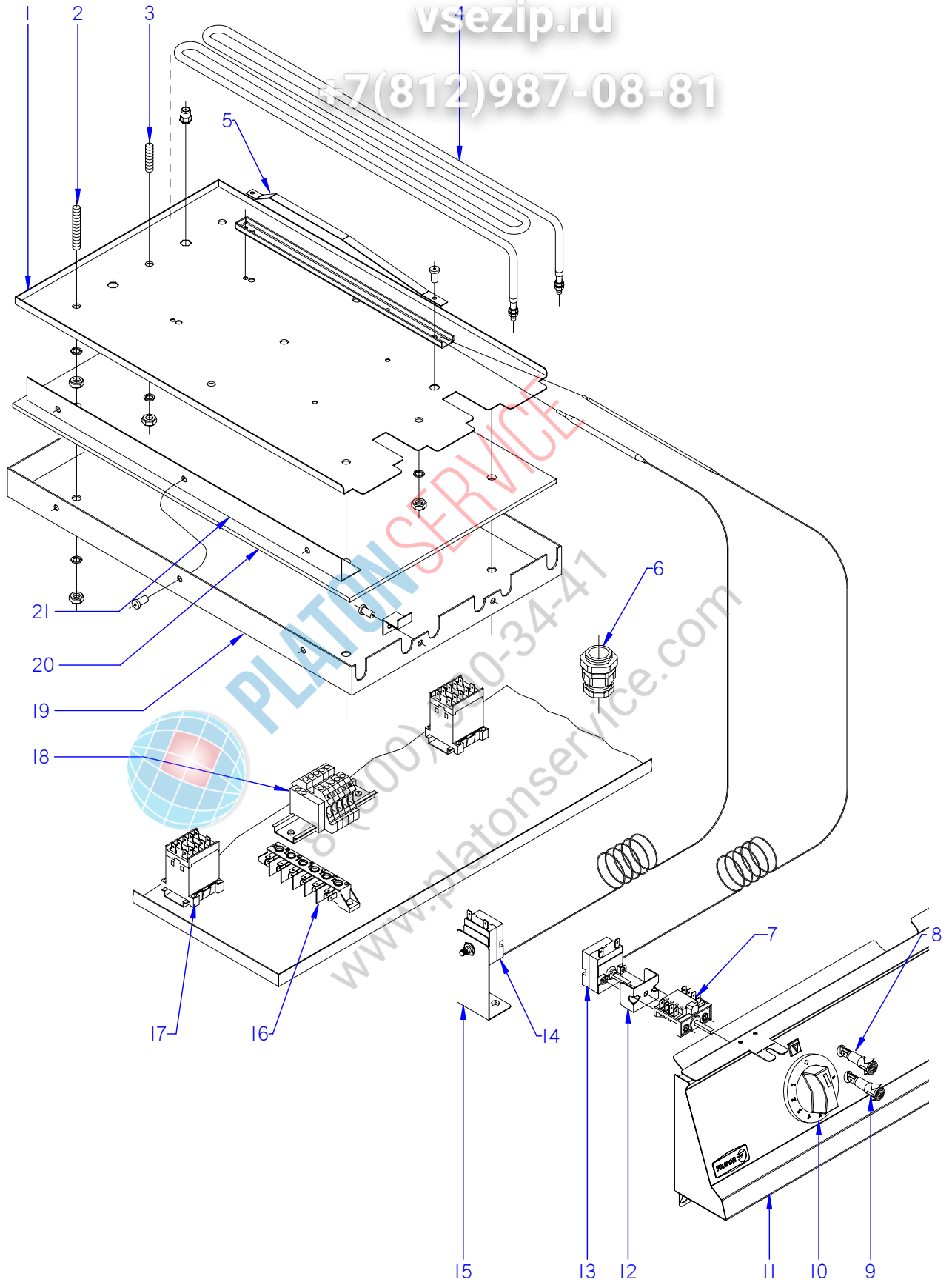

ITEM MARCADO EN COLOR = REPUESTO RECOMENDADO
COLOURED ITEM = RECOMMENDED SPARE PART

N plano	Firma	Fecha	Aparato	CONJUNTO FUNCIONAL	Lamina	Fagor Industrial S.Coop. FAGOR
C-2289	<i>(Signature)</i>	2009-03	FRY-TOP FTE9-05 / FTE9-10		2	Oñate

MOD.		FRY-TOP		ZONA		CONJUNTO FUNCIONAL			
ITEM	CODIGO	DENOMINACION	TEXTO	FTE9-05	FTE9-10				
1	R582601000	AMARRE RESISTENCIAS	RESISTOR FASTENING FTE9-05	1	1				
1	R592601000	AMARRE RESISTENCIAS	RESISTOR FASTENING FTE9-10	1	2				
	Q162050000	TUERCA EXAGONAL M8x1 INOX.	HEXAGONAL BOLT M8	9	18				
	Q221343000	REMACHE EXAGONAL M6	HEXAGONAL RIVET M6	2	4				
2	Q131557000	VARILLA ROSCADA M8X50	THREADED ROD M8X50	4	8				
3	Q131555000	VARILLA ROSCADA M8x30	THREADED ROD M8X30	5	10				
4	R573010000	RESISTENCIA FTE9-10	RESISTOR FTE9-10	3	6				
5	R592634000	SOPORTE BULBO FTE9-10	BULB SUPPORT FTE9-10	1	2				
S/Nº	R592631000	BASE SOPORTE BULBO FTE9-10	BASE BULB SUPPORT FTE9-10	1	2				
6	R013022000	PRENSA ESTOPAS	STUFFING BOX	1	1				
6	R023013000	PRENSA ESTOPAS PG-21	STUFFING BOX PG-21	1	1				
7	X163007000	CONMUTADOR ACOPLA TERMOS	THERMOSTAT CONNECT SWITC	1	2				
8	R693055000	PILOTO VERDE 41227000C7	GREEN PILOT 41227000C7	1	2				
8	12047390	PILOTO VERDE 230V AC 8KW 16MM	GREEN PILOT 230V AC 8KW 16M	1	2				
9	R693056000	PILOTO AMBAR 41227000A4	AMBER PILOT 41227000A4	1	2				
9	12024669	PILOTO AMBAR Ø18	AMBER PILOT Ø18	1	2				
10	U173005000	MANDO MONTADO Ø6	CONTROL BUTTON Ø6	1	2				
11	R052822000	PORTAMANDOS FTE9-05	CONTROL HOLDER FTE9-05	1	1				
11	R062822000	PORTAMANDOS FTE9-10	CONTROL HOLDER FTE9-10	1	1				
12	X313001000	U SOPORTE TERMOSTATO	THERMOSTAT U SUPPORT	1	2				
13	X153000000	TERMOSTATO 50-310 C	THERMOSTAT 50-310 C	1	2				
	Q151320000	TOR. ALOMADO M4X6 H.ZINCADO	CURVED SCREW M4X6 H. ZINC	2	4				
14	R612103000	TERMOSTATO LIMITADOR	THERMOSTAT LIMITER	1	2				
15	R572607000	SOPORTE LIMITADOR	LIMITER SUPPORT	1	2				
	Q419005000	REMACHE 4X8 ALMG3 / ALUMINIO	RIVET 4X8 ALMG3 / ALUMINIUM	2	4				
16	R253044000	REGLETA AUXILIAR FV-122	AUXILIARY TERMINAL STRIP FV-	1	2				
	Q152004000	TORNIL. APLASTADO M5X13 A 304	FLAT HEADED SCREW M5x13	2	4				
17	Z213007000	CONTACTOR 230 V. 50-60 HZ	CONTACTOR 230 V. 50-60 HZ	1	2				
	Z123018000	GUIA CONTACTOR L-55	CONTACTOR GUIDE L-55	1	2				
	Q419005000	REMACHE 4X8 ALMG3 / ALUMINIO	RIVET 4X8 ALMG3 / ALUMINIUM	2	4				

Зип Общежит

FTE-905 FTE-705

NOTAS

- Las inscripciones resistirán sin modificación apreciable el frotamiento durante 15 seg. de un algodón impregnado en gasolina.

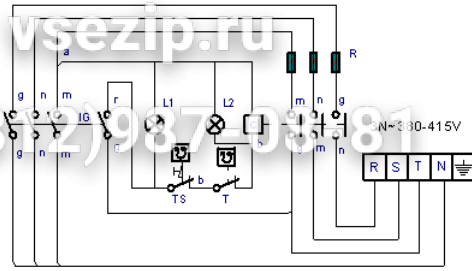

IG: Interruptor general
 L1: Lámpara funcionamiento
 T: Termostato regulable (50-310°C)
 L2: Lámpara calentamiento
 C: Contactor de calentamiento
 R: Resistencias
 TS: Termostato seguridad (400°C)

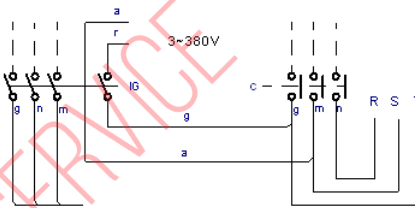
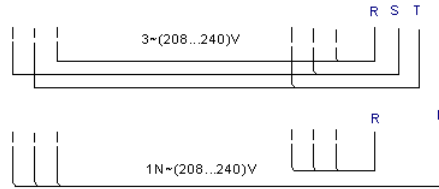

r = rojo-red-rouge
 m = marron-brown-marron
 g = gris-gre-gris
 n = negro-black-noir
 a = azul-blue-bleu
 b = blanco-white-blanc
 v = violeta-violette-violet
 am/v = amarillo/verde
 yellow/green
 jaune/vert



PLATON SERVICE
 8 (800) 500-34-41
 www.platonservice.com

Esquema teórico adhesivo				R-563000		
Nº	Pieza	Cant.	Material	Nº Clasificación	Acabado	
①	Introducir TS		Maillo	95-6-14	Tolerancias generales	
②	Introducir FTE-705		Etxeberria	1-7-97	5-25±	50-100
③	Introducir G-700		Etxeberria	8-7-97	25-50±	100-∞
Dibujado		Firma	Fecha	FAGOR 		Mecanizado superficial
Proyectado		JON	95-5-23	Fagor Industrial, Koop. Elk. Mugatua		
Comprobado		<i>Uteq</i>				
Escala		FRY-TOP				Plano numero
						HB-14936
		Plano hau ez dailike erabili ez berizta gura bainemilz gabe				Sustituye al N°
						Sustituido por

Зип Общесервис

BME 910, BME 710, BME 710 EA
FTE, FE 6 05, CMF 6-05

vsezip.ru

+7(812)984-1481

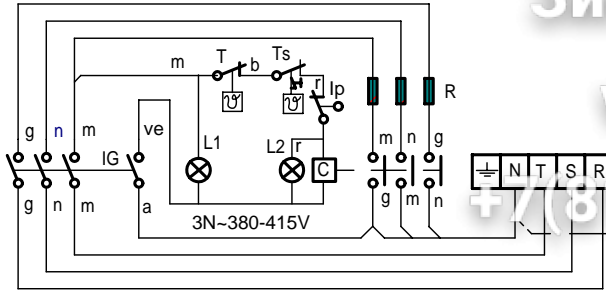

- r = rojo / red
- m = marron / brown
- g = gris / grey
- n = negro / black
- a = azul / blue
- b = blanco / white
- ve = verde / Green
- am/ve = amarillo-verde / Yellow-green

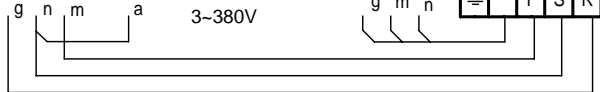
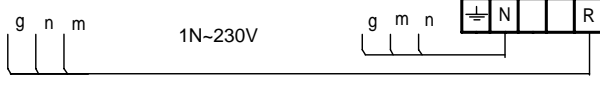
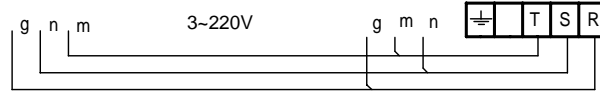

- IG : Interruptor general / Main switch
- IGV : Interruptor de Llenado / Switch electrovalvula water (Mod. EA)
- Ip : Interruptor de seguridad / Security switch (Mod. FE)
- L1 : Lámpara funcionamiento / Operating lamp
- L2 : Lámpara calentamiento / Heating Lamp
- C : Contactor de calentamiento / heating contactor
- R : Resistencia de Calentamiento / Resistance heating
- T : Termostato / thermostat
- Ts : Termostato de seguridad / Hi-limit thermostat
- V : Electrovalvua Agua / Water ElectroValve (mod. EA)

12002086



PLATON SERVICE

8 (800) 500-34-41

www.platonservice.com

-	Esquema teorico FE 605, FTE, CMF 605, BM 710, BM 910		J153003000	
Zk./Nº	Pieza	Cant.	Materiala/Material	Klas. zk/Nº Clas. Gainazal akabera/Tratamiento
Zk./Nº	Aldaketa/Modificaciones		Nork proposatua/Propuesta de	Data/Fecha
-	-	-	-	-
-	-	-	-	-
-	-	-	-	-
-	-	-	-	-
-	-	-	-	-
	Sinadura/Firma	Data/Fecha	 Fagor Industrial, Koop. Elk, Mugatua	
Marratzua/Dibujado	M.Maillo	2011-10-23		
Proiektatua/Proyectado	M.Maillo	2011-10-23		
Egiaztatua/Comprobado	J.Alberdi	2011-10-23		
Eskala/Escala	<h2>COOKING</h2>			Gainazal perdoia Mecanizado superficial
				Plano Zk./Plano Nº HB-80489
				- Zk. ord. du
	Plano hau ezin daiteke erabili, ez berriztatu, gure baimenik gabe.			- Zk.gaitik ord.

Зип Общепит

vsezip.ru

+7(812)987-08-81

FE 610, FTE 710, FTE 910

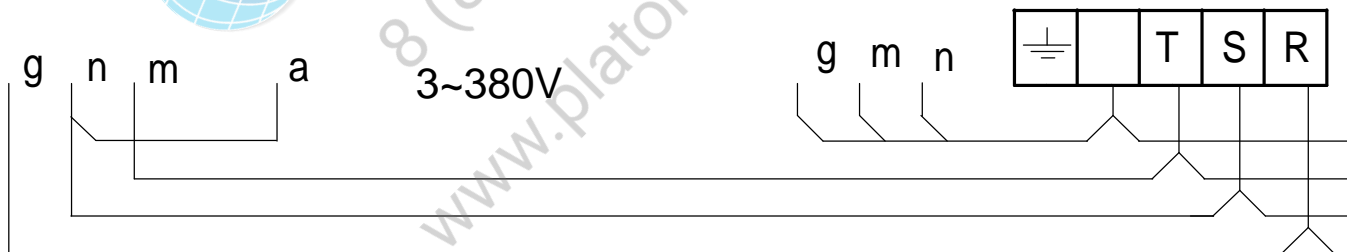
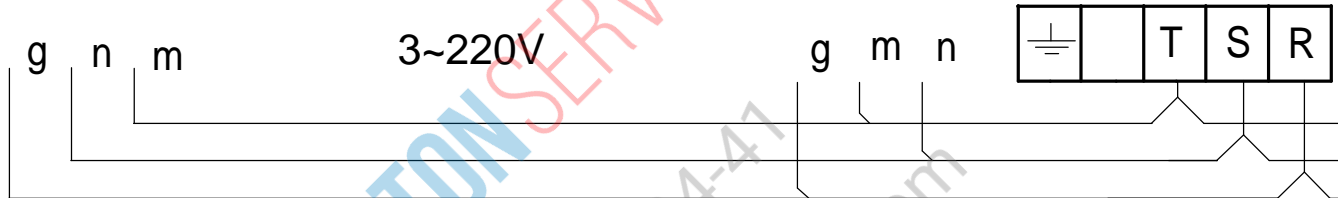
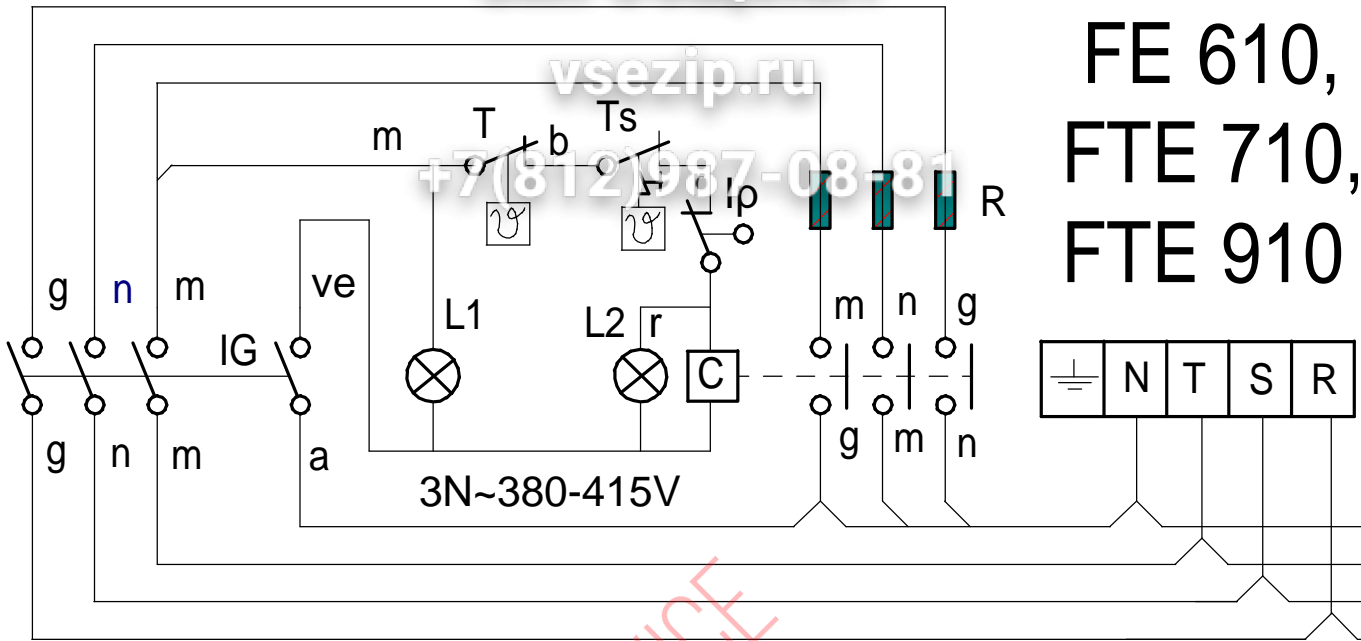

PLATON SERVICE
8 (800) 500-34-47
www.platonservice.com

Зип Общепит

FTE-710
Solos FTE-910

Topo 3 3 3
x3 P-453005
Azul Z-053302
P-453005

+7(812)987-08-81

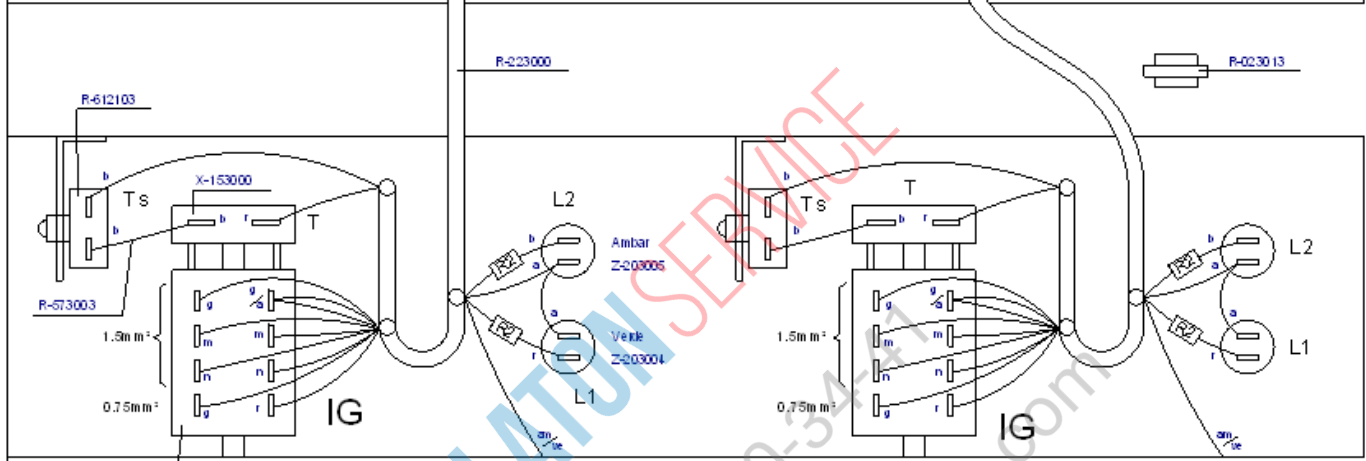
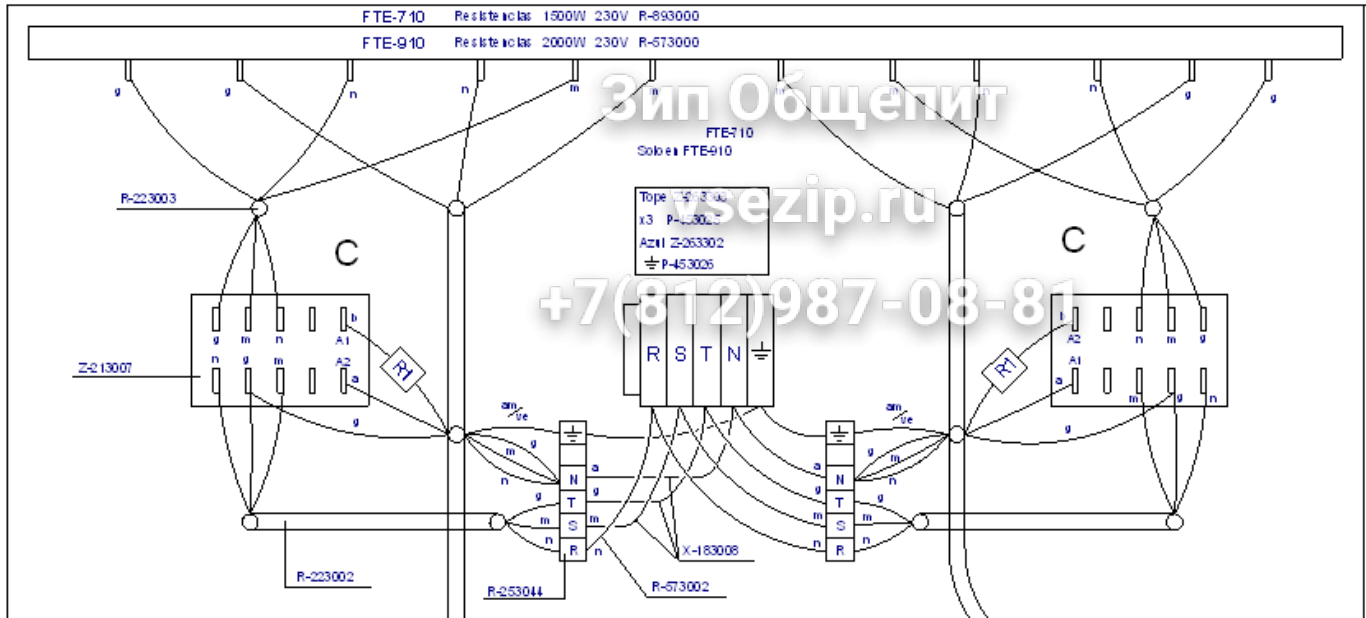

Esquema Adiestro
FTE-710 FTE-910 R-573001
FTE-705 FTE-905 R-563000

VERSION SIN NEUTRO
R2 U-803072 R-150x0mm 1/4W
R1 U-803073 R-81x20mm 6W
 En IG, el cable azul (0,75mm²) dejarse libre (Separado del cable Gris 1,5mm²)
 En C el cable azul loca e Imarra en R-223002

Esquema de montaje 3N ~ 380V		
Nº	Pieza	
Nº	Modificación	
1	Introducir G-700	
Dibujado	JO N	05-9-25
Proyectado		
Comprobado		
Ejecab		
	FRY	
	Tomo línea cable azul e Imarra en R-223002	